

FENIX 200 DCL

Rockwell | Brinell Hardness Testers

SEMI - **AUTOMATIC**



FENIX 200DCL

Fully digital Rockwell hardness testing

The FENIX 200 DCL, constructed around a rock solid C-frame, is equipped with a load cell, closed loop, force feedback test force application system. Perform your hardness test, by easily pressing the START button on the 5" industrial touch screen. Test results can be simply stored up to 50 readings.

The DCL version performs both on Rockwell as Brinell, one of the advantages of the closed loop system. The internal system can be easily serviced by removing the side and top covers, no need to turn the machine upside down.



HARDNESS SCALES



ROCKWELL 10kgf – 150kgf



BRINELL 10kgf – 187.5kgf



TECHNOLOGY OF TODAY

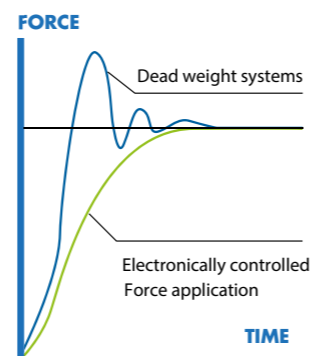

Load cell, closed loop, force feedback system

ROCKWELL & BRINELL FORCE RANGE

1kgf 10kgf FENIX 200 DCL 187.5kgf

HIGHLIGHTS

- 1 Load cell, closed loop, force feedback, force application system, error <0,25%
- 2 Rockwell scales : A | B | C | D | E | F | G | H | K | L | M | P | R | S | V
Brinell scales : HBW1/10 | HBW1/30 | HBW2.5/31.25 | HBW2.5/62.5 | HBW2.5/187.5
HBW5/25 | HBW5/62.5 | HBW5/125 | HBW5/187.5 | HBW10/100
- 3 5" Industrial touch screen for scale indication, dwell time countdown
- 4 Start/stop & menu selection buttons.
- 5 Large internal memory of 50 readings
- 6 Throat depth : 150mm
- 7 Working height : 260mm
- 8 Machine weight (net) : 104kg.
- 9 Machine dimensions : H765mm/W270mm/D555mm

SENSIBLE INNOVATION



200 DCL
Multi loadcell,
ball bearing,
force actuator



STANDARD
Force
adjustable
workpiece clamp

Observe, Think, Try, Change...

Unparalleled in this class of Rockwell hardness testing machines is the electronic Load cell, closed loop, force feedback, force application system. Absolute maintenance free, automatic setting of test forces by choosing the Rockwell hardness scale. Error free operation, due to an automatic test cycle, applying the main load and correct pre-set dwell time.

Innovative software functions

The I-Touch™ software provides clever multi-function keys for testing, set-up, storing and uploading of test programs, statistic control and more, making tester operation as easy as it can be.

Data export, single or batch readings, with a single press on a button, or just fully automatic over an USB connection to a PC and imported or evaluated in EXCEL. Further advanced features include extended statistics, shape correction for convex, concave or ball shaped specimens, hardness conversion to Rockwell, Brinell or Tensile strength according to ASTM E140 and ISO 18625 with different material tables.



OPERATING COMFORT WITH I-TOUCH

INNOVATIVE SOFTWARE FUNCTIONS

1 ACTIVE UPPER LIMIT



2 ACTIVE LOWER LIMIT

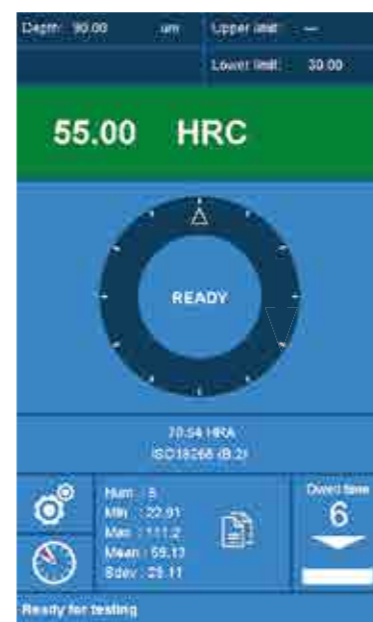

3 MEASUREMENT OVERVIEW

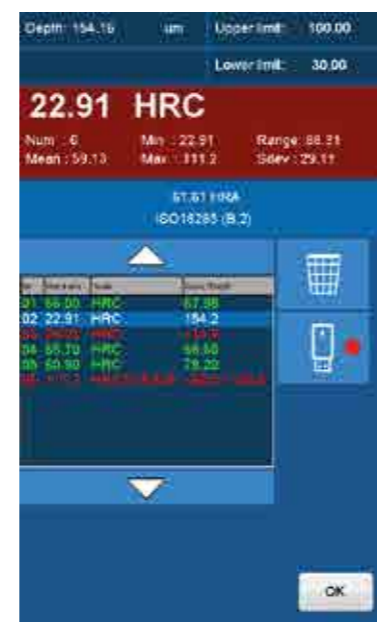

4 CONVERSION SCREEN

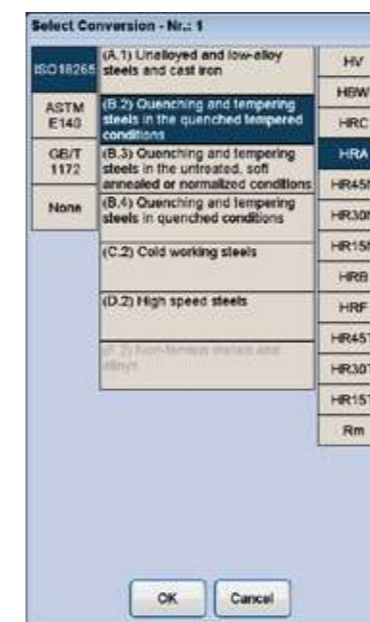

5 EXPORT FUNCTIONS

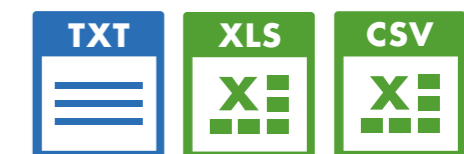



VARIOUS POSSIBILITIES

The FENIX 200 is larger than most other machines in its class. With a throat depth of 150mm and maximum workpiece height of 240mm, it offers the user a generous workspace. Moreover the FENIX 200 is super rigid, sturdy and can withstand the harshest environments. Compare these parameters with alternative products and find that FENIX is leading in its class.



INDENTER COVER & CLAMP

The FENIX 200 series is standard equipped with an indenter protection cover that includes an integrated spring loaded workpiece clamp pressing the workpiece firmly on the anvil and eliminating possible workpiece and spindle hysteresis. Adjustable clamp force, to avoid impressions on softer materials.



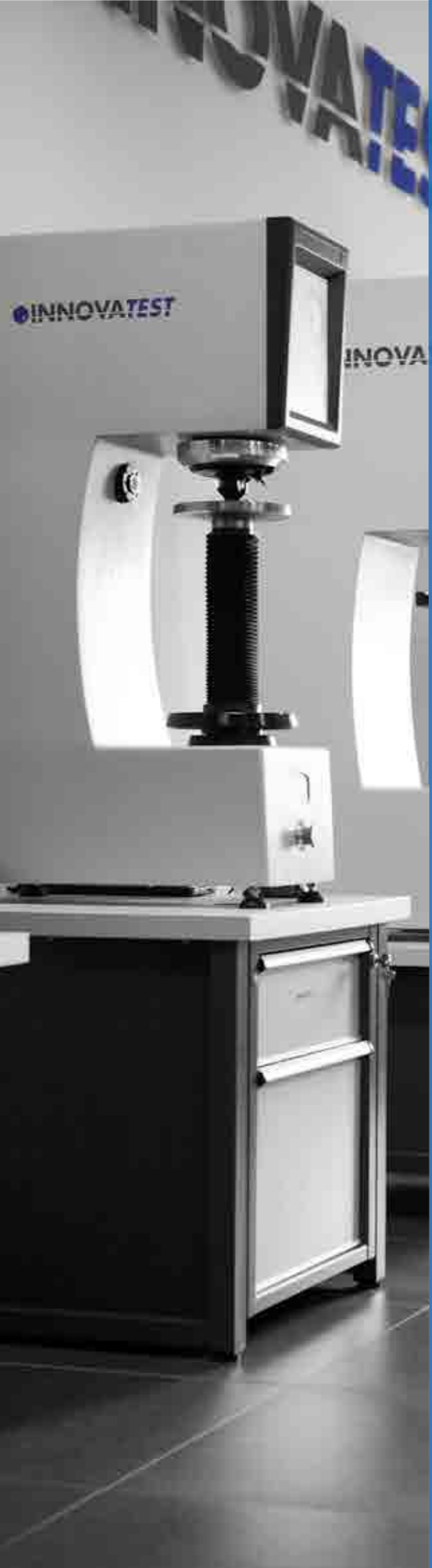

SUPPORT YOUR BEST TESTING RESULTS

With our rigid designed Bench stands

- Rock solid bench stands
- 100% retractable drawer, bearing guidance, max 100kg load. Rubber anti slip bottom
- Lockable cabinet, 300mm high
- Adjustable feet, (+/- 50mm height adjustable to reach ergonomic working position)
- Made of corrosion resistant zinc plated steel with RAL powder coating
- Carrying capacity of 400kg
- Top surface made of 50mm Plywood with 1.5mm chemical resistant plastic plating, edges made of shock resistant 3mm ABS side liner
- Industrial quality, for workshop or laboratory

Designed for hardness testing instruments, painted in INNOVATEST® RAL colors matching our testers.



UN-STAND/960 71 x 75 x 80 cm



UN-STAND/965 150 x 75 x 80 cm

ACCESSORIES FENIX 200

Schematic overview of the configuration options, standard and optional accessories

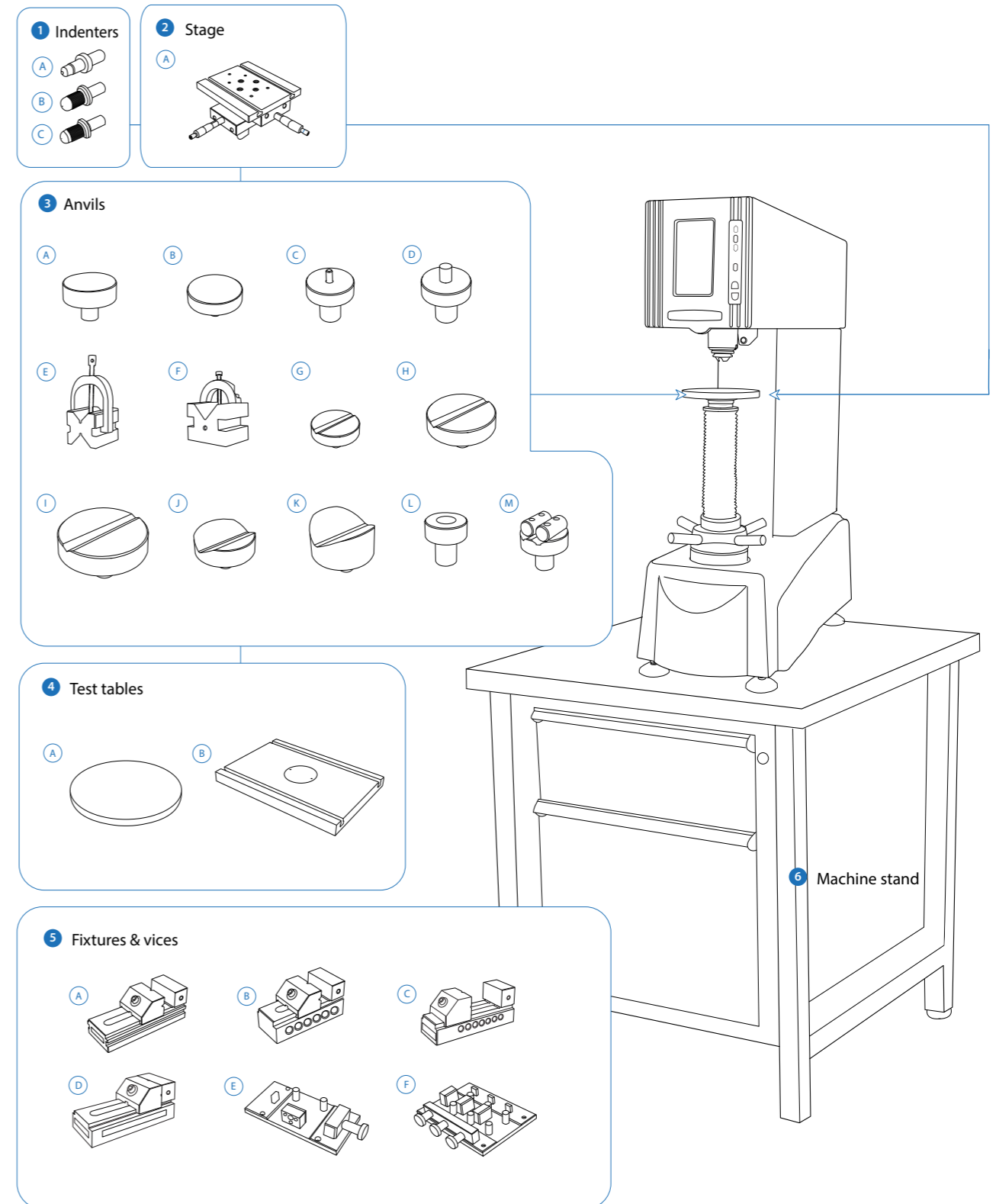

Not all accessories are displayed on this page. Full details can be found on the Order details page.

ORDER DETAILS

FENIX 200



Digital, Load Cell Closed Loop, Rockwell hardness tester 10kgf - 150kgf	FENIX 200DCL	
Plug & Play prepared, calibration, sea & airworthy packing in "non coniferous wood" material	P&PSEAPACK60	

ACCESSORIES

1	Indenters	A	Rockwell diamond indenter	IN/6005	
		B	1mm Carbide Ball Indenter Ø6.35mm	IN/7000	
			2.5mm Carbide Ball Indenter Ø6.35mm	IN/7005	
			5mm Carbide Ball Indenter Ø6.35mm	IN/7010	
			10mm Carbide Ball Indenter Ø6.35mm	IN/7015	
		C	1/16" Carbide Ball Indenter	IN/7506	
			1/8" Carbide Ball Indenter	IN/7606	
			¼" Carbide Ball Indenter	IN/7706	
2	Stages		Manual X-Y stage with analogue metric micrometers, 180x160mm Displacement: 25x25mm, scale 0.01mm, max load 300kg	UN-TESTTABLE/030	
			Lock flange	UN-XYZ BUSH42	
			Mounting plate for lock flange	UN-XYZ30FP40-42	
3	Anvils	A	Flat anvil 60mm	AS3000-19-04	
		B	Flat anvil 80mm	UN-TESTTABLE/002	
		C	Spot anvil 5mm	UN-ANVIL/010	
		D	Spot anvil 10mm	UN-ANVIL/011	
		E	V block with bracket 40x40x50mm (LxBxH)	UN-VBLOCK404050	
		F	Steel, cross type, (X) V-block 60x120x100mm 8-90mm pair	UN-CROSSBLOCK01	
		G	V-anvil ø40mm 6-60mm	UN-ANVIL/005	
		H	V-anvil ø63mm 6-60mm	UN-ANVIL/006	
		I	V-Anvil ø80mm 3.3-20mm	UN-ANVIL/040	
		J	V-Anvil ø80mm 12-80mm	UN-ANVIL/045	
		K	V-Anvil ø80mm 20-140mm	UN-ANVIL/050	
		L	Anvil for round specimen dia. 6-25,4mm	UN-ANVIL/200	
		M	Cylindrical V anvil 6-80mm	UN-CVANVIL680	
			Cylindrical V anvil 50-200mm	UN-CVANVIL50200	
4	Test Tables	A	Testing table flat ø180mm, screwfix	ASV700-00-20	
			Testing table flat ø235mm, screwfix	UN-TESTTABLE/014	
		B	Large flat surface testing table 350x250mm, thickness 30mm with 2 T-slots, for large components	UN-TESTTABLE/015	
			Lock flange	ASV700-21-01	

5	Fixtures and Vices	A	Polished precision vice with lock down system, jaw width 25mm, opens 20mm	UN-VICE/210	
		B	Polished precision vice with lock down system, jaw width 36mm, opens 42mm	UN-VICE/215	
		C	Polished precision vice with lock down system, jaw width 48mm, opens 75mm	UN-VICE/220	
		D	Polished precision vice with lock down system, jaw width 75mm, opens 100mm	UN-VICE/230	
		E	JOMINY Fixture, for 1 quench end test sample, quick release function	UN-JOMFIX1	
		F	JOMINY Fixture, for 3 quench end test sample, quick release function	UN-JOMFIX3	
6	Machine Stand		Cabinet test table with drawer for hardness testers 71x75x80cm	UN-STAND/960	
			Seaworthy packing box for 950/960	PACK/100	
			Direct and Indirect Verification/Calibration & BRINELL Certification in compliance with ISO & ASTM, NADCAP.	CALCEFRDW/1B	
			Direct and Indirect Verification/Calibration & ROCKWELL Certification in compliance with ISO & ASTM, NADCAP.	CALCEFRDW/1R	
	Cover	Anti Static machine cover 320x550x800mm	UN-TESTERCOVER05		

SOFTWARE

	Connectivity Plus	Interface cable for PC	UN-CABLE/910	
		Utility software; Import test results in MS applications like Excel	UN-SW/905	

ACCESSORIES

INDENTERS



STAGES



TEST TABLES



ASV700-00-20
UN-TESTTABLE/014



UN-TESTTABLE/015

ANVILS



FIXTURES AND VICES



MACHINE STANDS



UN-STAND/960

SPECIFICATIONS

HARDNESS SCALES

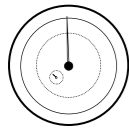
	ROCKWELL EN-ISO 6508, ASTM E-18 JIS Z 2245	A B C D E F G H K L M P R S V
	BRINELL* EN-ISO 6506, ASTM E92 JIS Z 2243	HBW1/30 HBW2.5/31.25 HBW2.5/62.5 HBW2.5/187.5 HBW5/25 HBW5/62.5 HBW5/125 HBW10/100 * FENIX 200ACL only

TEST FORCE

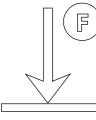
	Force application	Load cell, closed loop, force feedback system
	Test forces	Preload : 10kgf, main loads : 15.625 25 30 31.25 60 62.5 100 125 150 187.5kgf
	Force range	FENIX 200DCL 10kgf – 187.5kgf
	Test force tolerance	< 0.25% for test force 10kgf to 187.5kgf
	Dwell time settings	Default 10 seconds, user defined. Up to 999 seconds

GENERAL

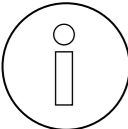
	Machine dimension	765mm x 270mm x 555mm
	Machine weight	104kg
	Power supply	100VAC to 240VAC, 50/60Hz, single phase
	Operating temperature	10°C to 35°C, non-condensing
	Power consumption	10W
	Humidity	10% to 90%, non-condensing

TECHNICAL DRAWINGS

All dimensions in these drawings are in mm, approximate. Working heights and or workpiece accommodation varies depending on the stages and stage accessories used.

Please contact our sales department for more details.

FENIX 200DCL

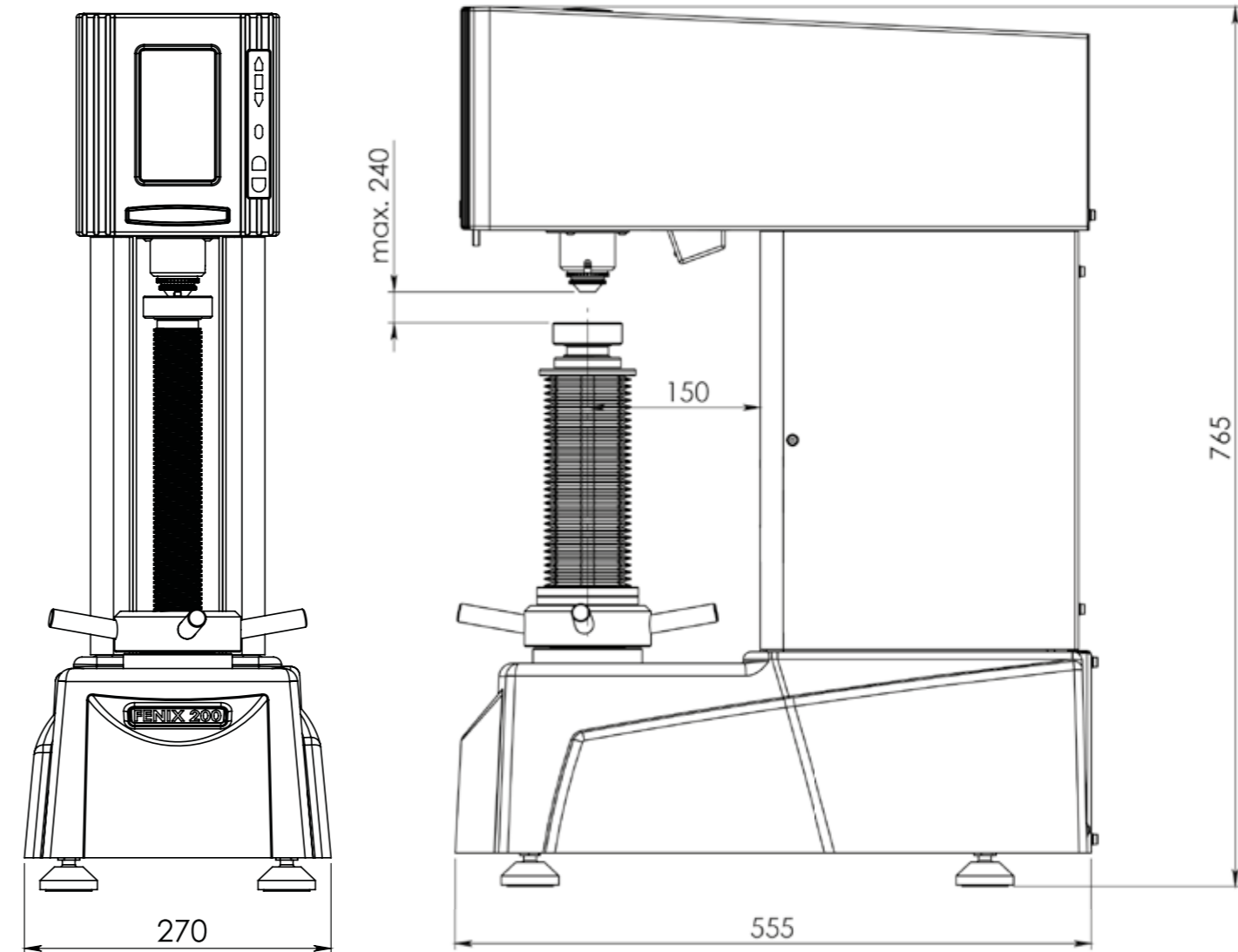

OTHER MODELS IN THE ROCKWELL RANGE



NEXUS 605

Load Cell, closed loop
Rockwell/Superficial Rockwell/
Brinell hardness tester,
with full color touch
screen.
See brochure B18N605/XX



NEXUS 610

Load Cell, closed loop
Rockwell/Superficial Rockwell/
Brinell hardness tester,
with integrated PC,
Windows 10, wifi etc.
full color touch screen.
See brochure B18N610/XX



VERZUS 710

Load Cell, closed loop
Rockwell/Superficial Rockwell/
Brinell hardness tester, with
direct depth measuring system,
integrated PC, Windows 10,
wifi, full color touch screen.
See brochure B18V710/XX



NEMESIS 6100

Load Cell, Closed loop
Fully automatic Rockwell/
Superficial Rockwell
(Brinell) hardness tester
with descending test head
& fixed workpiece position.
full color touch screen
operation.
See brochure B18N6100/XX



NEMESIS 6200

Load Cell, Closed loop
Fully automatic Rockwell/
Superficial Rockwell (Brinell)
hardness tester with
descending test head & fixed
workpiece position, integrated
PC, Windows 10, Wifi, full color
15" industrial capacitive touch
screen.

Includes CNC motorized
X-Y stage, overview camera
and advanced software
(IMPRESSIONS) for automatic
pattern testing and fixture
recognition.
See brochure B18N6200/XX

www.innovatest-europe.com

Changes in products and/
or product specifications
can emerge due to new
technologies and continuous
development.

We reserve the right to change
or modify specifications of
the products without prior
notice. We recommend you
to contact our sales office for
up-to-date information.

Brochure B18F200DCL/01/EN

© All rights reserved, 2018

Distributor :

CORPORATE HEAD OFFICE

INNOVATEST Europe BV

Manufacturing, Distribution & Service

Borgharenweg 140
6222 AA MAASTRICHT
The Netherlands

Phone: +31 43 3520060

Fax: +31 43 3631168

info@innovatest-europe.com

www.innovatest-europe.com

INNOVATEST Deutschland GmbH Sales & Service

Phone: +49 245 670 59 500
info@innovatest-deutschland.com
www.innovatest-deutschland.com

INNOVATEST Polska sp. z.o.o Sales & Service

Phone: +48 697 099 826
info@innovatest-polska.pl
www.innovatest-polska.pl

INNOVATEST Shanghai Co., Ltd. Sales & Service

Phone: +86 21 60906200
info@innovatest-shanghai.com
www.innovatest-shanghai.com

INNOVATEST Japan Co., Ltd. Sales & Service

Phone: +81 3 3527 3092
info@innovatest-japan.com
www.innovatest-japan.com

INNOVATEST USA Company Sales & Service

Phone: +1 267 317 4300
info@innovatest-usa.com
www.innovatest-usa.com

INNOVATEST South East Asia Sales & Service

Phone: +65 6451 1123
info@innovatest-singapore.com
www.innovatest-singapore.com